

REV. NO.	DATE	DESCRIPTION	APP'D	REMARKS
△	-	-	-	-

0

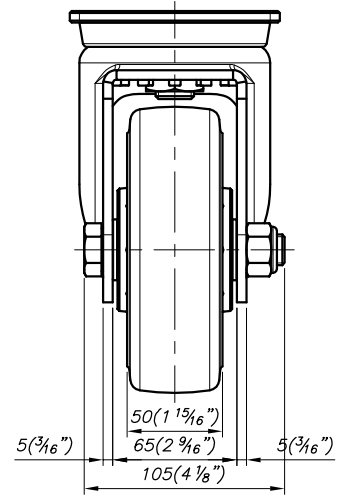
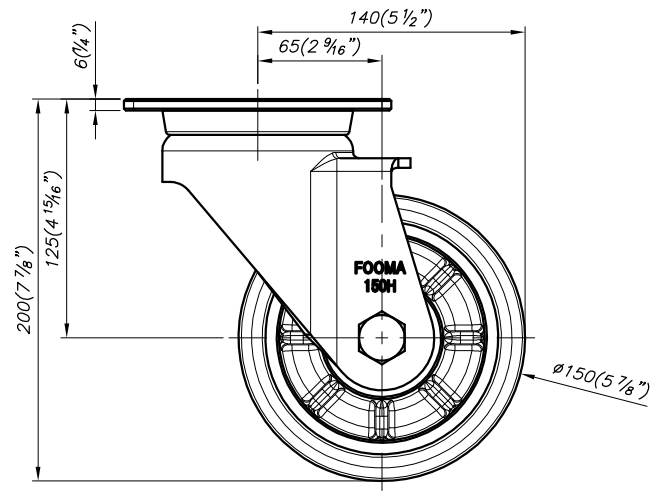
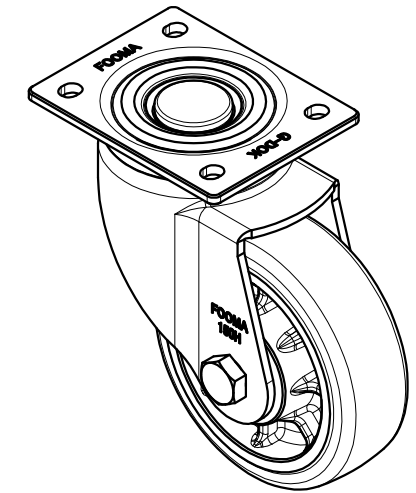
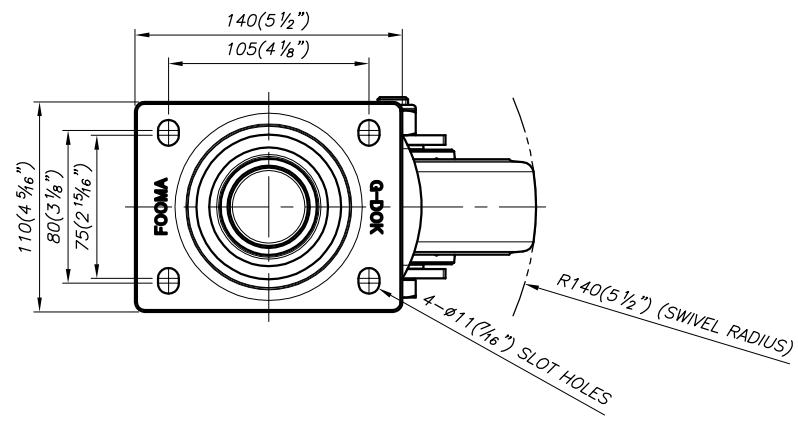

**NOTE**

- ±1) LOAD CAPACITY : 700KG/EA
- ±2) SURFACE TREATMENT : POWDER COATED & ZINC GALVANIZED

PROCESS		MATERIAL		APPROVED BY		CHECKED BY		DRAWN BY	
---		---		O.C.K		J.Y.H		J.T.H	

GENERAL TOLERANCE									
MACHINING WORKING		DIE CASTING		ELECTRON BEAM WELDING		PRESS WORKING		UNIT	
FINISH	PRESION	FINISH	PRESION	FINISH	PRESION	FINISH	PRESION	mm	mm
0.5 - 6	±0.05	±0.1	±0.1	±0.05	±0.1	±0.05	±0.1	mm	mm
6 - 30	±0.1	±0.2	±0.2	±0.05	±0.1	±0.05	±0.1	mm	mm
30 - 120	±0.15	±0.3	±0.3	±0.05	±0.1	±0.05	±0.1	mm	mm
120 - 400	±0.2	±0.5	±0.5	±0.05	±0.1	±0.05	±0.1	mm	mm
400 - 1000	±0.3	±0.8	±0.8	±0.05	±0.1	±0.05	±0.1	mm	mm

FOOT MASTER®		FOOMA®		G-DOK IND.	
SERIES NAME	GHP-SERIES	DATE	2024.04.26	GSN NO.	5E111-211111
PRODUCT NAME	GHP-150-ASF-MUD-PEU	SCALE	1/3	DWG. NO.	5E111-211111
PART NAME	ASSEMBLY	WEIGHT	---	REVISION	SIZE A3
		GENERAL TOLERANCE	B	ANGLE	△

FOOT MASTER G-DOK IND. FOOT MASTER G-DOK IND.

REV. NO.	DATE	DESCRIPTION	APP'D	REMARKS
1	-	-	-	-

0

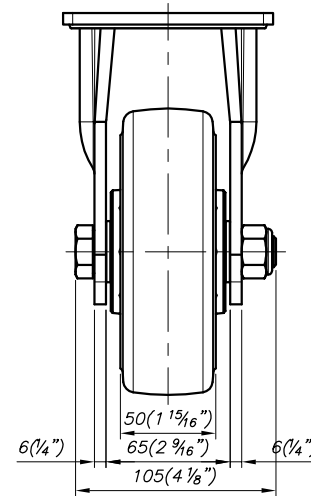
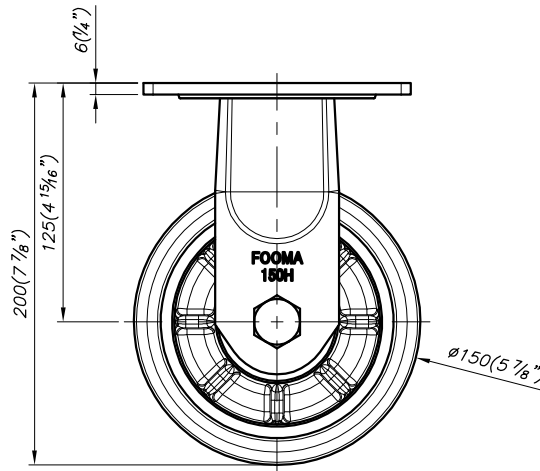
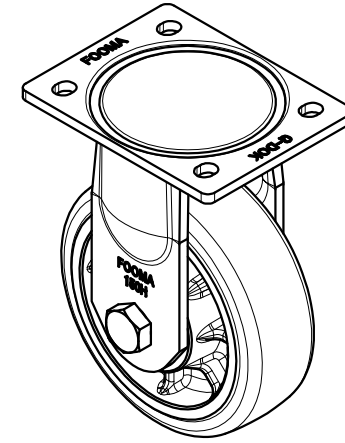
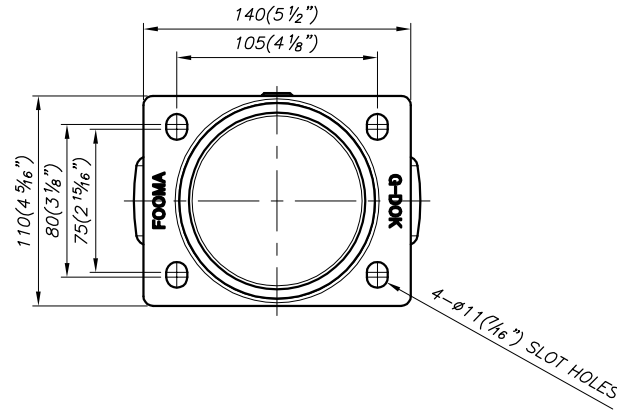

**NOTE**

- ±1) LOAD CAPACITY : 700KG/EA
- ±2) SURFACE TREATMENT : POWDER COATED & ZINC GALVANIZED

PROCESS		GENERAL TOLERANCE									
MATERIAL		MACHINING WORKING		DE CASTING		ELECTRON BEAMING		PRESS WORKING			
APPROVED BY	CHECKED BY	DRAWN BY	FINISH	PRESION	GENRAL	FINISH	PRESION	GENRAL	FINISH	PRESION	GENRAL
O.C.K	J.Y.H	J.T.H	0.5-6	±0.05	±0.1	1-10	±0.05	±0.1	1-10	±0.05	±0.1
			6-30	±0.1	±0.2	10-30	±0.1	±0.2	10-30	±0.1	±0.2
			30-120	±0.15	±0.3	30-100	±0.15	±0.3	30-100	±0.15	±0.3
			120-400	±0.2	±0.5	100-300	±0.2	±0.5	100-300	±0.2	±0.5
			400-1000	±0.3	±0.8	300-800	±0.3	±0.8	300-800	±0.3	±0.8

FOOT MASTER®		FOOMA®		G-DOK IND.	
SERIES NAME	GHP-SERIES	DATE	2024.04.26	GSN NO.	5E121-211111
PRODUCT NAME	GHP-150-ARF-MUD-PEU	SCALE	1/3	DWG. NO.	5E121-211111
PART NAME	ASSEMBLY	WEIGHT	--	REVISION	SIZE A3
		GENERAL TOLERANCE	B	ANGLE	⚠

FOOT MASTER G-DOK IND. FOOT MASTER G-DOK IND.

REV. NO.	DATE	DESCRIPTION	APP'D	REMARKS
1	-	-	-	-

0

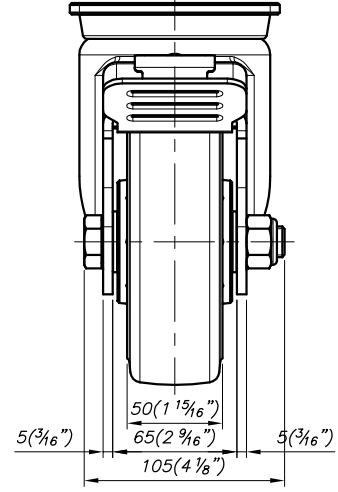
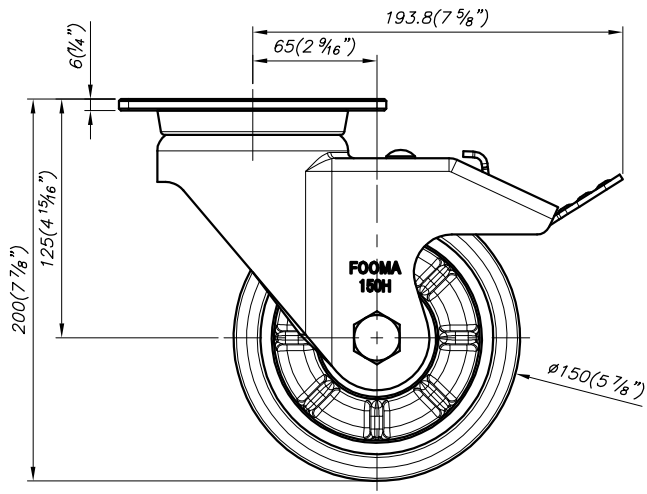
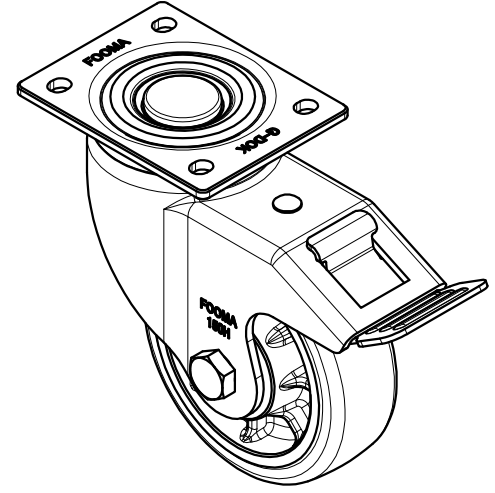
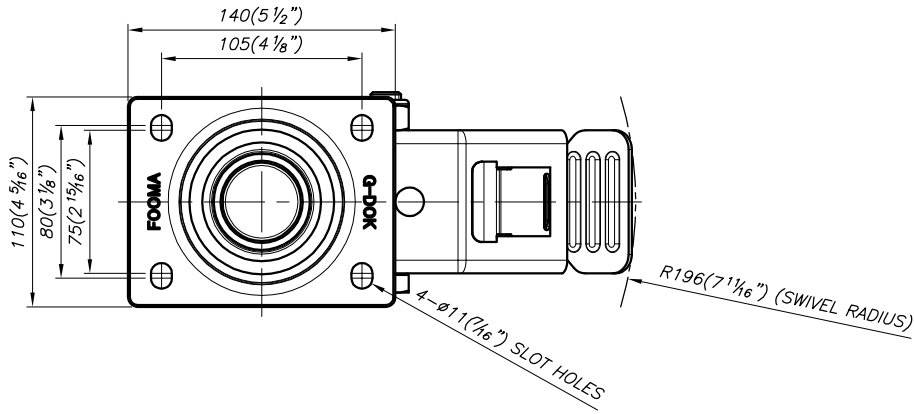

**NOTE**  
 1) LOAD CAPACITY : 700KG/EA  
 2) SURFACE TREATMENT : POWDER COATED & ZINC GALVANIZED

PROCESS		GENERAL TOLERANCE																	
MATERIAL		MACHINING FINISHING				DE CASTING				ELECTRON BEAM WELDING				PRESS BURNING					
APPROVED BY	CHECKED BY	DRAWN BY	PRODUCT GENERAL TOLERANCE																
CENTER HEIGHT	INTEL OUTER DIAMETER	INTEL INNER DIAMETER	0.5 - 30	30 - 120	120 - 400	400 - 1000	0.5 - 30	30 - 120	120 - 400	400 - 1000	0.5 - 30	30 - 120	120 - 400	400 - 1000	0.5 - 30	30 - 120	120 - 400	400 - 1000	
O.C.K	J.Y.H	J.T.H																	

FOOT MASTER®		FOOMA®		G-DOK IND.	
SERIES NAME	GHP-SERIES	DATE	2024.04.26	GSN NO.	5E131-211111
PRODUCT NAME	GHP-150-BSF-MUD-PEU	SCALE	1/3	DWG. NO.	5E131-211111
PART NAME	ASSEMBLY	WEIGHT	--	REVISION	SIZE A3
		GENERAL TOLERANCE	B	ANGLE	

FOOT MASTER G-DOK IND.