

REV. NO.	DATE	DESCRIPTION	APP'D	REMARKS
△	-	-	-	-

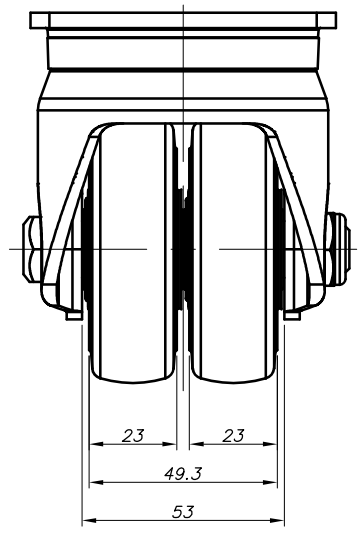
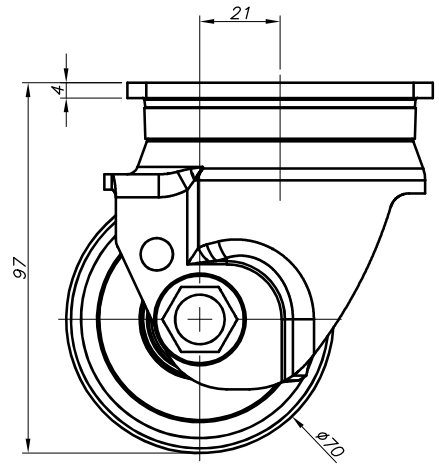
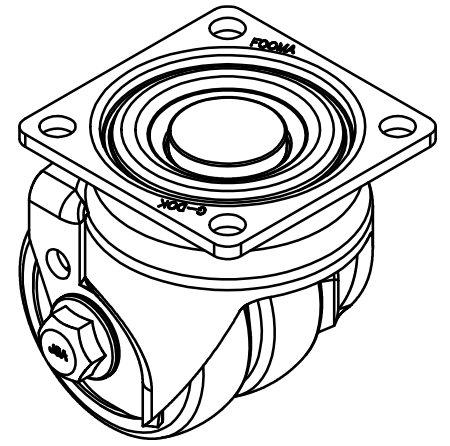
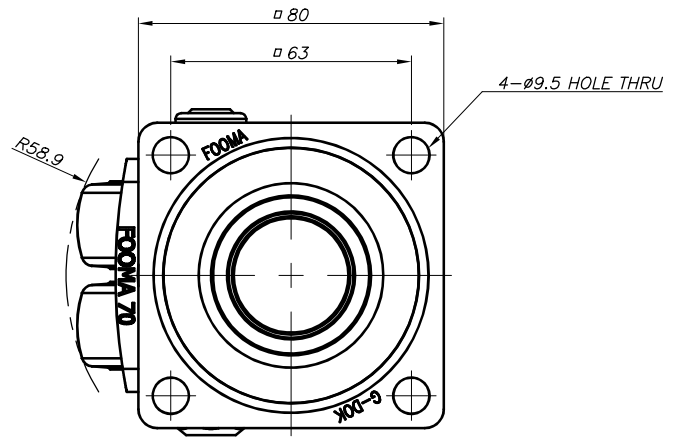

NOTE
 ※ 1) --

PROCESS		MATERIAL		APPROVED BY		CHECKED BY		DRAWN BY	
---	---	---	---	O.C.K	J.Y.H	J.Y.S			

GENERAL TOLERANCE									
MACHINE WORKING		DIE CASTING		WELDING		PRESS WORKING		UNIT	
MINI	PRESION	GENRAL	MINI	PRESION	GENRAL	MINI	PRESION	GENRAL	mm
0.5 - 6	±0.05	±0.1	P-R	AS	P-R	AS	P-R	AS	
6 - 30	±0.1	±0.2	P-R	AS	P-R	AS	P-R	AS	
30 - 120	±0.15	±0.3	P-R	AS	P-R	AS	P-R	AS	
120 - 400	±0.2	±0.5	P-R	AS	P-R	AS	P-R	AS	
400 - 1000	±0.3	±0.8	P-R	AS	P-R	AS	P-R	AS	

PRODUCT GENERAL TOLERANCE					
CASTER HEIGHT		WELL OUTER DIAMETER		WELL INNER WIDTH	
±0.05	±0.1	±0.05	±0.1	-0.05	-0.1
±0.1	±0.2	±0.1	±0.2	-0.1	-0.2

NO.	DESCRIPTION	UNIT	Q'TY	MATERIAL	WEIGHT	SPECIFICATION	REMARKS
--	--	--	--	--	--	--	--

FOOT MASTER®			FOOMA®			G-DOK IND.			
SERIES NAME	AGV-SERIES	DATE	2023.07.28	GSN NO.	-	SCALE	N/S	DWG. NO.	-
PRODUCT NAME	GAUSD-70-ASF-HUD-PIP	WEIGHT	---	REVISION		GENERAL TOLERANCE	B	ANGLE	△
PART NAME	ASSEMBLY								

FOOT MASTER G-DOK IND.