

REV. NO.	DATE	DESCRIPTION	APP'D	REMARKS
1	-	-	-	-

0

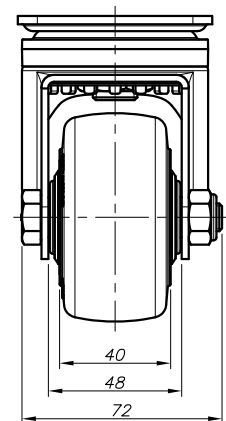
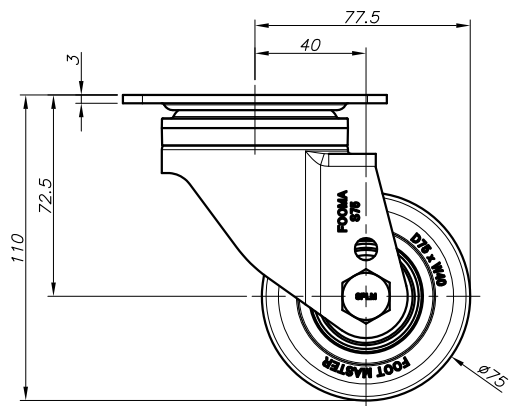
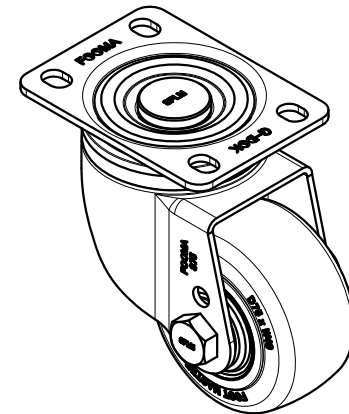
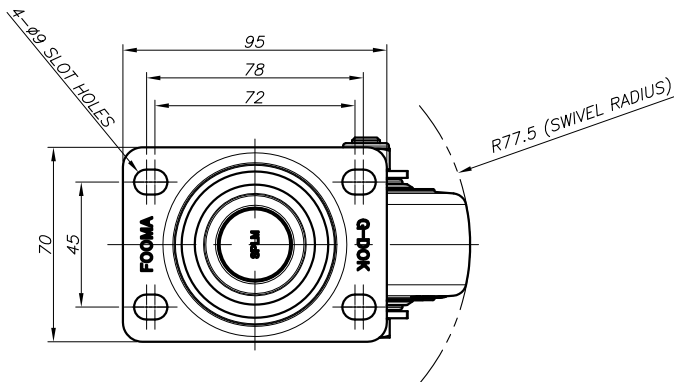

NOTE  
 1) MATERIAL : STAINLESS

NO.	DESCRIPTION	UNIT	Q'TY	MATERIAL	WEIGHT	SPECIFICATION	REMARKS
--	--	-	-	-	-	-	-

PROCESS	--	
MATERIAL	--	
APPROVED BY	CHECKED BY	DRAWN BY
O.C.K	J.Y.H	K.S.J

FOOT MASTER®		FOOMA®		G-DOK IND.	
SERIES NAME	SPLM-SERIES	DATE	2025.02.19	GSN NO.	39111-111111
PRODUCT NAME	SPLM-75-ASF-HRD	SCALE	1/2	DWG. NO.	39111-111111
PART NAME	ASSEMBLY	WEIGHT	--	REVISION	SIZE A3
GENERAL TOLERANCE	B	ANGLE			

FOOT MASTER G-DOK IND.

REV. NO.	DATE	DESCRIPTION	APP'D	REMARKS
1	-	-	-	-

0

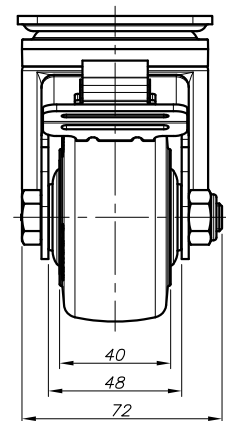
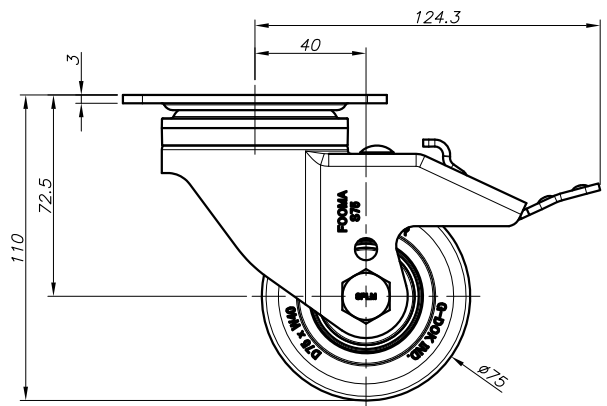
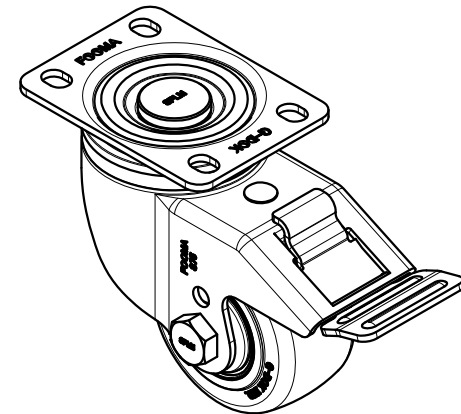
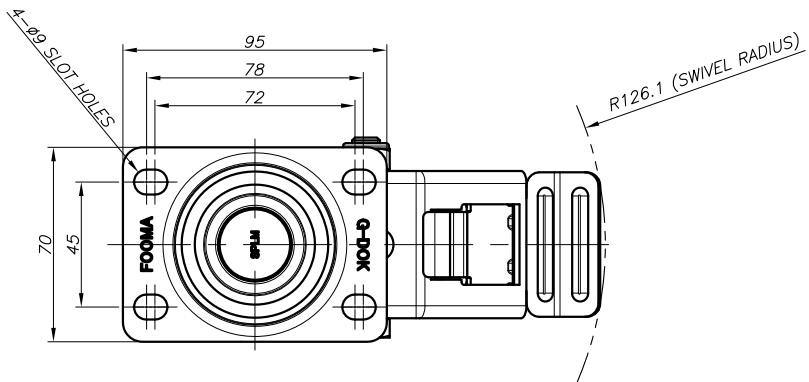

NOTE  
 1) MATERIAL : STAINLESS

PROCESS	GENERAL TOLERANCE											
MATERIAL	MACHINING WORKING			DIE CASTINGS			INJECTION MOLDING			PRESS WORKING		
	FINISH	PRECISION	CONVEX	FINISH	PRECISION	CONVEX	FINISH	PRECISION	CONVEX	FINISH	PRECISION	CONVEX
	0.5 - 6	±0.05	±0.1	P-3	H1	H2	P-3	H1	H2	P-3	H1	H2
	6 - 30	±0.1	±0.2	P-3	H1	H2	P-3	H1	H2	P-3	H1	H2
	30 - 120	±0.15	±0.3	P-3	H1	H2	P-3	H1	H2	P-3	H1	H2
	120 - 400	±0.2	±0.5	P-3	H1	H2	P-3	H1	H2	P-3	H1	H2
	400 - 1000	±0.3	±0.8	P-3	H1	H2	P-3	H1	H2	P-3	H1	H2

APPROVED BY	CHECKED BY	DRAWN BY	PRODUCT GENERAL TOLERANCE		
			CASTER HEIGHT	WHEEL OUTER DIAMETER	WHEEL HUB WIDTH
O.C.K	J.Y.H	K.S.J	6 - 30	±0.1	±0.2
			30 - 120	±0.15	±0.3
			120 - 400	±0.2	±0.5
			400 - 1000	±0.3	±0.8

FOOT MASTER®		FOOMA®		G-DOK IND.	
SERIES NAME	SPLM-SERIES	DATE	2025.02.19	GSN NO.	39131-111111
PRODUCT NAME	SPLM-75-BSF-HRD	SCALE	1/2	DWG. NO.	39131-111111
PART NAME	ASSEMBLY	WEIGHT	--	REVISION	SIZE A3
		GENERAL TOLERANCE	B	ANGLE	⊕

FOOT MASTER G-DOK IND.

REV. NO.	DATE	DESCRIPTION	APP'D	REMARKS
1	-	-	-	-

0

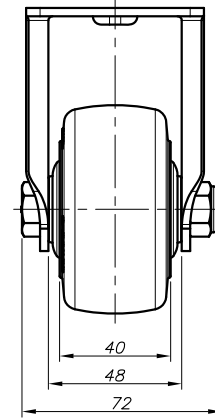
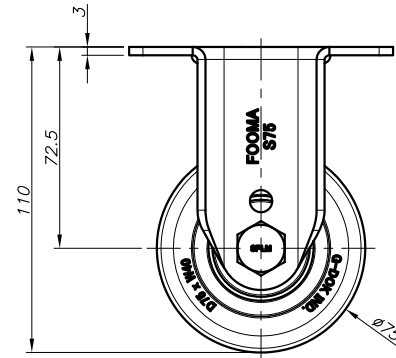
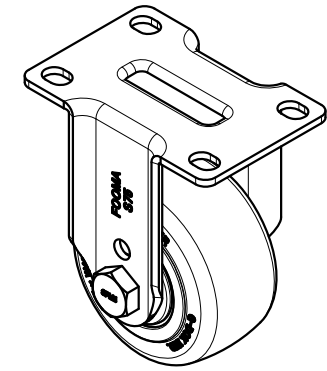
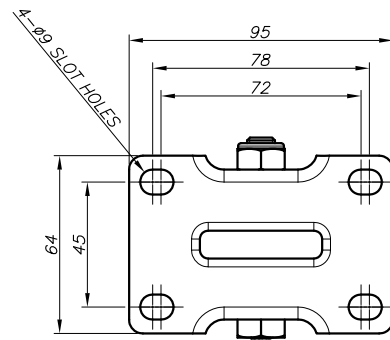

NOTE  
 1) MATERIAL : STAINLESS

PROCESS		MATERIAL		APPROVED BY		CHECKED BY		DRAWN BY	
---		---		O.C.K		J.Y.H		K.S.J	

SERIES NAME		DATE		GSN NO.	
SPLM-SERIES		2025.02.19		39121-111111	
PRODUCT NAME		SCALE		DWG. NO.	
SPLM-75-ARF-HRD		1/2		39121-111111	
PART NAME		WEIGHT		REVISION	
ASSEMBLY		---		---	

GENERAL TOLERANCE		CHAMFER		ROUND		UNT		mm	
MACHINING WORKING		0.5		0.5		0.5		0.5	
DIE CASTING		0.5		0.5		0.5		0.5	
INJECTION MOLDING		0.5		0.5		0.5		0.5	
PRESS WORKING		0.5		0.5		0.5		0.5	

PRODUCT GENERAL TOLERANCE		DIE CASTING		INJECTION MOLDING		PRESS WORKING	
SIZE	PRECISION	SIZE	PRECISION	SIZE	PRECISION	SIZE	PRECISION
0.5 - 6	±0.05	0.5 - 6	±0.1	0.5 - 6	±0.1	0.5 - 6	±0.1
6 - 30	±0.1	6 - 30	±0.2	6 - 30	±0.2	6 - 30	±0.2
30 - 120	±0.15	30 - 120	±0.3	30 - 120	±0.3	30 - 120	±0.3
120 - 400	±0.2	120 - 400	±0.4	120 - 400	±0.4	120 - 400	±0.4
400 - 1000	±0.3	400 - 1000	±0.5	400 - 1000	±0.5	400 - 1000	±0.5

FOOT MASTER G-DOK IND.