

REV. NO.	DATE	DESCRIPTION	APP'D	REMARKS
▲	-	-	-	-

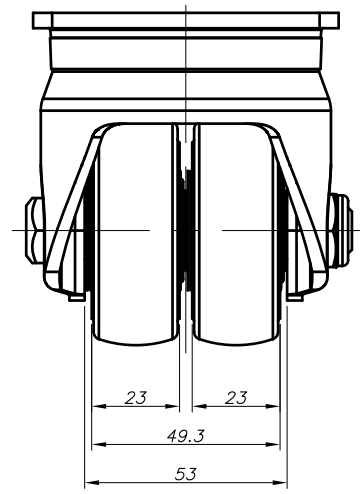
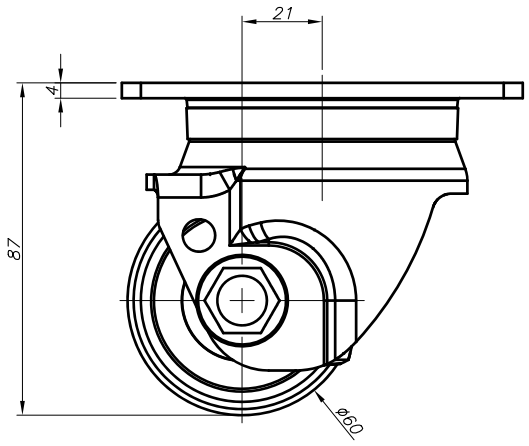
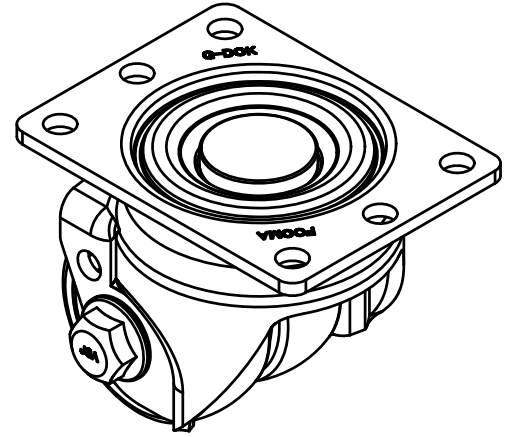
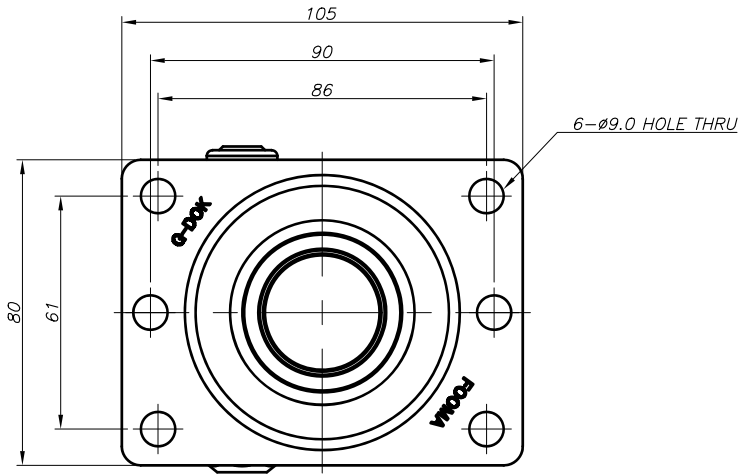

NOTE

※1) --

PROCESS			GENERAL TOLERANCE															
MATERIAL			MACHINING WORKING				DIE CASTING				INJECTION MOLDING				PRESS WORKING			
APPROVED BY	CHECKED BY	DRAWN BY	FINISH	PRESION	GENRAL	FINISH	PRESION	GENRAL	FINISH	PRESION	GENRAL	FINISH	PRESION	GENRAL	FINISH	PRESION	GENRAL	
O.C.K	J.Y.H	J.Y.S	0.5-6	±0.05	±0.1	1-3	±0.1	±0.2	1-3	±0.1	±0.2	1-3	±0.1	±0.2	1-3	±0.1	±0.2	
			6-30	±0.1	±0.2	3-5	±0.1	±0.2	3-5	±0.1	±0.2	3-5	±0.1	±0.2	3-5	±0.1	±0.2	
			30-120	±0.15	±0.3	3-5	±0.1	±0.2	3-5	±0.1	±0.2	3-5	±0.1	±0.2	3-5	±0.1	±0.2	
			120-400	±0.2	±0.5	3-5	±0.1	±0.2	3-5	±0.1	±0.2	3-5	±0.1	±0.2	3-5	±0.1	±0.2	
			400-1000	±0.3	±0.8	3-5	±0.1	±0.2	3-5	±0.1	±0.2	3-5	±0.1	±0.2	3-5	±0.1	±0.2	

FOOT MASTER®		FOOMA®		G-DOK IND.	
SERIES NAME	AGV-SERIES	DATE	2023.07.28	GSN NO.	-
PRODUCT NAME	GAJSD-60-ASF-HUD	SCALE	N/S	DWG. NO.	-
PART NAME	ASSEMBLY	WEIGHT	--	REVISION	
		GENERAL TOLRANCE	B	ANGLE	▲

FOOT MASTER G-DOK IND.